

Harbormaster Outboard Drives



Picking a SW-3000 for installation



...and under way within one hour.

SELF-CONTAINED PROPULSION SYSTEMS FOR BOATS & BARGES

A Distinguished History

Harbormaster developed the first heavy-duty marine outdrives in 1939. These economical, easily-moved power packages have met critical worldwide needs ever since. They have propelled everything from landing craft to ferry boats to coal barges. Many are still at work today. Harbormaster's experienced engineering staff continues to update these proven workhorses with the latest technology and materials to make them even more versatile and reliable.

A Design That Works

It is simplicity itself - a complete engine/drive/steering system that mounts on the deck of a boat or barge. No separate engine room, through-hull shafting, fuel tank or control station is required. Just fasten it in place, fill it with fuel and you're under way. Or move it to another vessel if necessary.

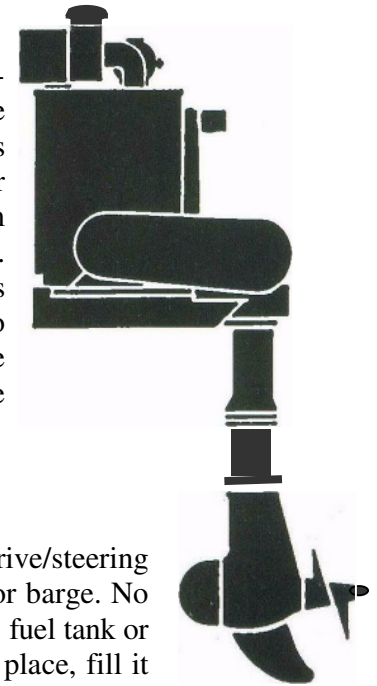

FEATURES

BENEFITS

<p><u>Mechanical Drive</u> This efficient system uses a positive drive belt, steel gears and shafts to transmit engine power to the propeller with minimum energy loss. Engine speed determines vessel speed.</p>	<ul style="list-style-type: none"> • High thrust per HP of input • Greatest fuel economy • Belt absorbs engine/drive shock • No constant high-RPM noise
<p><u>Hydraulic Steering</u> The lower unit can be rotated to 360 degrees, driven by a fast-response hydraulic control. No rudder or shaft rotation reversal is required.</p>	<ul style="list-style-type: none"> • Pinpoint positioning of vessel • Maximum thrust in any direction • Propeller always rotates in the same and most efficient direction
<p><u>Hydraulic Raising</u> The lower unit can be elevated up to 90 degrees for shallow water operation or inspection.</p>	<ul style="list-style-type: none"> • Drive can ride over shallows • Simplified repair of underwater components
<p><u>"Sidewinder" Design</u> The engine is transverse mounted relative to the drive system.</p>	<ul style="list-style-type: none"> • Requires minimum deck space • Permits greater cargo room
<p><u>Lower Unit Kick up</u> The hold-down releases and raises the unit if underwater obstacles are contacted.</p>	<ul style="list-style-type: none"> • Avoids damage to drive system and propeller
<p><u>Diesel Engines</u> Radiator-cooled power units from 60 to 200 HP are available.</p>	<ul style="list-style-type: none"> • Economical, reliable power • Parts and service readily available

Harbormaster Outboard Drives

DESIGNED AND BUILT TO PROVIDE RELIABILITY AND DURABILITY

HIGHEST QUALITY COMPONENTS AND EXTRA HEAVY-DUTY CONSTRUCTION MEAN

• LESS DOWNTIME • LOW-COST MAINTENANCE • LONG SERVICE LIFE

Engineering Data

Series	Power Range	Input Speed Range	Propeller Diameter	Propeller Speed Range	Approximate Weight (Dry)
2000	60-120 HP	1800-2800 RPM	30-40 IN	538-660 RPM	6000 LB
	45-90 KW		600-1016 MM		2722 KG
3000	120-200 HP	1800-2500 RPM	36-44 IN	435-587 RPM	7710 LB
	90-149 KW		914-1117 MM		3497 KG

Included in the patented designs are:

- Matched forged steel gear sets
- Tapered roller bearings
- Pressurized oil for lubrication & cooling
- SAE 4140 steel shafting
- Special seals
- Precisely engineered shim sets
- Bronze components where required
- Low weight chassis constructed of rectangular tubing for high degree of stiffness

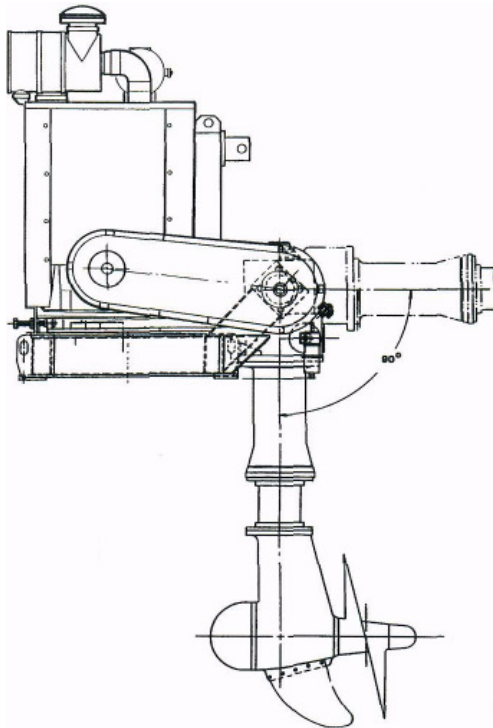

Options

- Stem lengths to suit individual vessel drafts
- Auxiliary fuel tank
- Remote control capability
- Anti-cavitation plate, if propeller tip submergence is a problem
- Marine transmission for reverse propeller rotation (Model SWR)

FAST WORLDWIDE SUPPORT!

Parts & service are available for all Murray & Tregurtha and Harbormaster units whether built in 1939 or today. Technical support is offered to customers by phone, fax or on-line. On-site field service anywhere in the world is provided by Harbormaster trained staff.



Harbormaster Marine, Inc.

37654 Amrhein Road • Livonia, MI 48150 • (734) 425-1080 • Fax (734) 425-1850

Web Site: www.harbormastermarine.com